

mu

USER'S MANUAL

(Rev. 02/2018)

edbi

ELEMENTI

stems and handlebars

STEMS AND HANDLEBARS



Thank you for choosing a DEDA ELEMENTI or MUD product.

We at DEDA ELEMENTI develop, manufacture, and constantly test our products in order to maintain the highest standards of quality.

We ask for your collaboration to preserve and correctly use DEDA ELEMENTI and MUD components.

To achieve this, we invite you to read these instructions carefully and retain this manual for future use. If you sell your DEDA ELEMENTI or MUD bicycle or components to someone else, please include this manual.

CONTENTS

ENG

1	WHAT IS VERY IMPORTANT FOR YOUR SAFETY? _____	pag. 4
2	LIMITS OF USE AND COMPATIBILITY TEST _____	pag. 5
3	INFORMATION ON PERIODIC CHECKS, USE, AND REPLACEMENT NEEDS OF DEDA ELEMENTI AND MUD COMPONENTS _____	pag. 6
4	GENERAL NOTES ON INSTALLATION _____	pag. 7
5	FITTING THE HANDLEBAR STEM ON THE FORK STEERER _____	pag. 8
6	HEADSET ADJUSTMENT _____	pag. 10
7	HANDLEBAR INSTALLATION _____	pag. 11
8	FITTING THE BRAKE-SHIFTER LEVERS ON THE DEDA ELEMENTI HANDLEBARS _____	pag. 13
9	CLEANING AND CARE _____	pag. 14
10	WARRANTY TERMS _____	pag. 14

WHAT IS VERY IMPORTANT FOR YOUR SAFETY?

- DEDA ELEMENTI and MUD recommend components be only installed and adjusted by qualified mechanics at your local DEDA ELEMENTI dealer. Our staff is trained, constantly updated, and familiar with the peculiarities of the DEDA ELEMENTI products, their recommended fittings and performance limitations.
- Use only a torque wrench to tighten the bolts and carefully follow the recommended tightening torques in this manual! Remember that the torque value printed on the components indicate the maximum recommended torque! Please never exceed the indicated torque value!
- DEDA ELEMENTI and MUD components are designed to operate properly within a tightening range of 4 to 5 N • m! If these values must be exceeded in order to avoid relative rotation of the fork steerer, stem, and handlebar, carefully check that surfaces are absolutely free of grease or other lubricants. Grease will drastically reduce the friction between the surfaces, forcing dangerous over-tightening of the bolts. If the problem persists please contact your DEDA ELEMENTI reseller or headquarters.

When tightening the bolts without using a torque wrench, you will systematically tend to underestimate the tightening torque. You will therefore overtighten the bolts. It is important to remember that overtightened bolts will not lead to a greater security of the assembly, but on the contrary will put excessive stress on the components, drastically reducing their fatigue life, causing breaking or cracking conditions that can have serious consequences on your life.

If you are in an emergency and cannot use a torque wrench, make sure the bolts are tight enough just to prevent relative rotation of the components, and please contact your DEDA ELEMENTI reseller immediately for a torque measurement.

- Before any ride, follow this simple checklist, which allows you to prevent most possible problems:
 - 1) Make sure that the fork steerer rotates properly, it is adjusted to the proper and usual headset play, and the stem does not rotate on the fork steerer.
 - 2) Make sure the handlebar does not rotate in the stem's handlebar clamp.
 - 3) Check the faceplate clamping bolts. Make sure they are all in place and undamaged, and the faceplate has no cracks or abrasions.
 - 4) Check the fork steerer clamping bolts. Make sure they are all in place and undamaged, and the seats show no signs of cracking or abrasions.

- Do not use the bicycle if handlebar, stem, or seatpost exhibit creaking noises or if you notice damage such as cuts, cracks, bulges, dents, discolorations, etc. Please have your authorized DEDA ELEMENTI dealer carefully inspect these damages and if necessary, replace the components.
- Please refer regularly to www.dedaelementi.com to receive information about any additional recommendations, updating campaigns, or recalls of defective products.

2

LIMITS OF USE AND COMPATIBILITY TEST

The DEDA ELEMENTI components are designed and tested according to the specific conditions of use to the various genres of cycling, as classified on the DEDA ELEMENTI catalogue available at www.dedaelementi.com. Please follow strictly the following indications:

- Please choose and use the DEDA ELEMENTI and MUD components according to the intended use.
- Do not use any road components (ROAD series) for all-terrain use.
- Do not use the DEDA ELEMENTI and MUD components for Freeride, Dual Slalom, Downhill, or generally for all applications that are outside the scope of testing provided by EN14766 and EN14781 standards.
- Before purchase and installation, please make sure the components are compatible:
 - 1) Stem steerer clamp diameter/steerer diameter
(MAX ALLOWED TOLERANCE 0.20 mm.)
 - 2) Faceplate diameter/handlebar diameter
(MAX ALLOWED TOLERANCE 0.20 mm.)
- The DEDA ELEMENTI handlebar stems are designed to be fitted solely with DEDA ELEMENTI handlebars.
- The DEDA ELEMENTI handlebars are designed to be fitted solely with DEDA ELEMENTI stems.
- DEDA ELEMENTI handlebars and handlebar stems are designed to carry at maximum a fully equipped rider's weight of 242 lbs. (110 kg).

After the components' first fitting and break-in (generally after the first 100-250 km), use a torque wrench to check the correct tightening of all the bolts. If needed, loose the bolts and re-tighten to the correct torque.

- Bolts that are too tight or too loose can cause serious accidents that can lead to serious injuries or death.
- DEDA ELEMENTI and MUD components are designed to operate properly within a tightening range of 4 to 5 N • m! If you must exceed these values in order to avoid relative rotation of fork steerer, stem and handlebar, please contact your DEDA ELEMENTI reseller or headquarter.

Please repeat this check at least every 1500 km.

All bicycle components are subject to wear and properties and performance deterioration, based on your bicycle care and maintenance and on the environmental conditions to which the bike is exposed, e.g. rain, mud, dust and sand.

Metal parts are particularly sensitive to atmospheric corrosion, while parts made of composite material are especially sensitive to the direct exposure to sunlight, extreme temperatures, and impact.

Every two years, or every year in the case of intensive use, please have a qualified DEDA ELEMENTI mechanic remove the handlebar, stem and fork steerer to inspect them for integrity.

No component should exhibit cracks, cuts, or abrasions. If in doubt, do not hesitate to contact DEDA ELEMENTI.

- Accidents, impacts or drops can produce cracking or delamination in composite components which may not be readily visible, and give rise to sudden failures over time. These can cause serious accidents that can lead to serious injuries or death. Composite components can not be repaired. Therefore, in the event of accident, impact or drop, discard and replace the affected composite component.

- Accidents, impacts, or drops can produce microcracks in metal components which may grow into fatigue cracks not readily visible, and give rise to sudden failures over time.

These can cause serious accidents that can lead to serious injuries or death. DEDA ELEMENTI and MUD metal handlebars, stems, and faceplates are made of hard aluminum alloy. If bent as a result of impact or drop, they cannot be straightened. They **MUST** be replaced.

GENERAL NOTES ON INSTALLATION

The installation of the DEDA ELEMENTI or MUD components should be performed only by a qualified DEDA ELEMENTI mechanic.

He has the expertise and the equipment required to safely assemble the DEDA ELEMENTI and MUD products for you and the environment.

Each of the following indications must be carefully observed. Failure to comply with instructions may cause component failure and result in serious accidents that can lead to serious personal injuries or death and will void the warranty.

- We recommend you always use DEDA ELEMENTI and MUD handlebar and stem together because they are designed and manufactured for the best performance and reliability.
- If you intend to use a third party component together with a DEDA ELEMENTI or MUD product, please carefully read the manufacturer's instructions for use and make sure it fits well and can be used safely with DEDA ELEMENTI and MUD components.
- In the event of discrepancy between the manuals, always use the lower recommended torque.
- DEDA ELEMENTI and MUD components are designed to operate properly within a tightening range of 4 to 5 N • m! If you must exceed these values in order to avoid relative rotation of fork steerer, stem and handlebar, this means the assembled components are not compatible, or that grease and dirt have deteriorated the friction properties of surfaces.

DEDA ELEMENTI assumes no responsibility for problems from using a DEDA ELEMENTI and MUD component with a component from another manufacturer, and cannot guarantee that fatigue life and regulatory compliance properties of the complete DEDA ELEMENTI and MUD assemblies will be retained.

FITTING THE HANDLEBAR STEM ON THE FORK STEERER

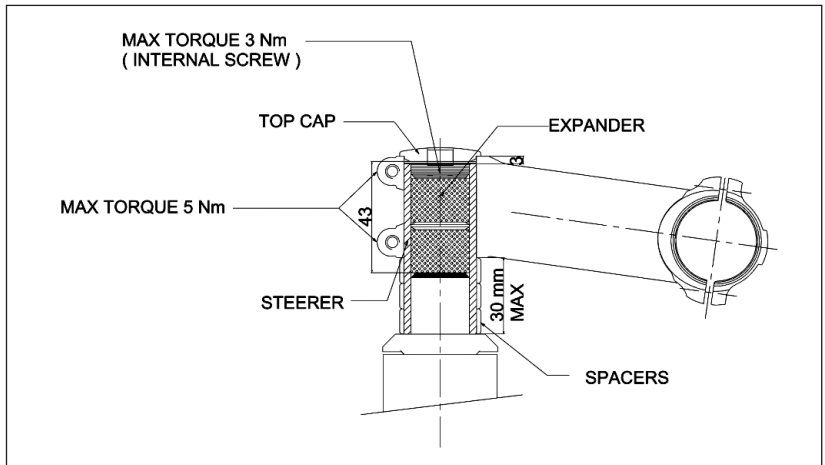

The drawing above shows the correct fitting of the handlebar stem on the fork steerer. Cutting the fork steerer to size is a delicate operation and can release harmful particles, irreparably damaging the fork itself if done without the proper equipment.

- For the first fitting of a DEDA ELEMENTI or MUD handlebar stem, which involves the cutting to size of the fork steerer, please contact your authorized dealer DEDA ELEMENTI.

If you are instead replacing a stem, make sure that the diameter of the handlebar stem fits the fork steerer.

Make sure that the replacement stem's stack height is not greater than the original stem stack height. Carefully inspect the existing fork steerer for strictures, notches, and, if made of composite material, fiber tears or other damages. If there is visible damage please immediately contact a specialized mechanic.

- Transverse cuts on the fork steerer at the edge of the handlebar stem, expander or bearing are very dangerous fracture initiators. Please replace fork immediately!
- Make sure that the expander (not included) has enough length to ensure the handlebar stem rear bolts seat on the expander portion of the fork steerer. This will reduce the risk of fork steerer notching while tightening the rear bolts.

Thoroughly clean the surfaces in order to remove any dirt and grease.
Depending on the length of the fork steerer and on the desired handlebar stem position, you may need to install spacers above the headset.
Maximum spacer height is 30 mm.
The spacers are available in different heights.
The stack height must position the top of the fork steerer 2 mm below the top of the handlebar stem.
Make sure that the distance from the top of the handlebar stem to the top of the fork steerer is no greater than 3 mm.
Some DEDA ELEMENTI and MUD handlebar stems (flip-flop reversible graphics) can be mounted regardless of the angle formed by the fork steerer.
This allows you to fit the handlebar at two different heights using the same handlebar stem.
Do not put spacers above the stem!
The lower lip of the stem exerts pressure on an area not supported by the expander which will cause fork steerer ovalization and notching and serious risks for your safety: the steerer could suddenly break under stress!

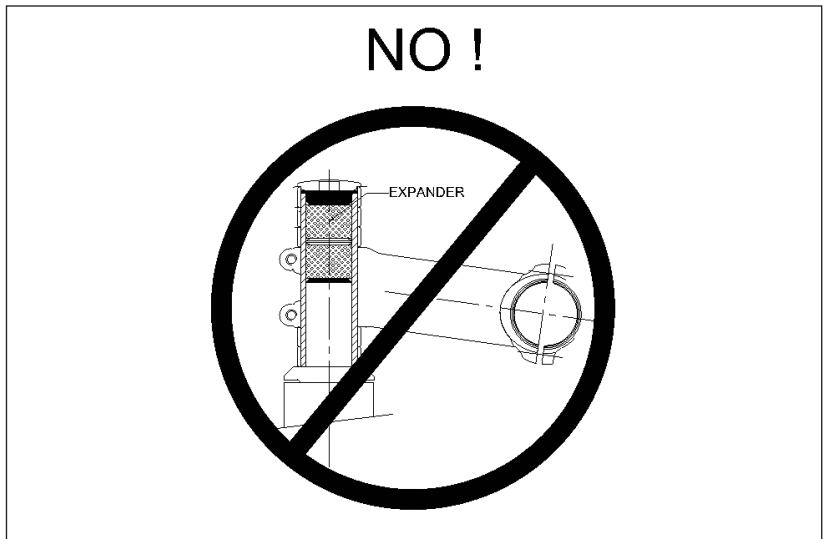

Install the expander in the fork steerer until it stops, and tighten the expansion bolt at maximum torque of 3 N • m.
Tighten the top cap, which adjusts the bearing play.

HEADSET ADJUSTMENT

Adjusting the headset is a delicate procedure for which we recommend you contact your DEDA ELEMENTI reseller.

If you decide to adjust the headset play yourself, please read carefully the instructions described in the operation and maintenance manual of the headset you use and in the operation and maintenance manual of the fork your bike is equipped with.

- To adjust the bolts always use a torque wrench and follow carefully the recommended tightening torques in this manual!

Remember that in the event of discrepancies, you should always use the lower recommended torque.

Loosen the handlebar stem steerer clamp bolts without unscrewing them completely, so that the handlebar stem can slide along the fork steerer. By turning the bolt located on the top cap you can adjust the bearing play.

CAUTION! Overtightening can damage the ball bearings, which could bind under stress!

Once the headset play has been adjusted, check the handlebar stem orientation, which must be perfectly set in relation to the direction of travel. The handlebar will then exactly be at a right angle to the direction of travel. Alternately tighten the two rear stem bolts in an alternating pattern using a torque wrench starting with a minimum torque of 4 N•m. If the handlebar stem is not tight enough, increase the torque up to a maximum of 5 N•m. Please check the handlebar stem, which should not rotate on the fork steerer.

- DEDA ELEMENTI and MUD components are designed to operate properly within a tightening range of 4 to 5 N•m! If, in order to avoid relative rotation of fork steerer, stem and handlebar you must exceed these values, this means that the assembled components are not compatible, or that grease and dirt have deteriorated the friction properties of the surfaces.

CAUTION! use the minimum handlebar stem bolts torque required to ensure that the handlebar stem does not rotate on the fork steerer (Max. 5 N•m).

An unnecessarily high torque generates a dangerous state of radial compression on the fork steerer which can crack and/or break without notice.

HANDLEBAR INSTALLATION

Before starting the installation of a DEDA ELEMENTI or MUD handlebar please check the handlebar compatibility with the stem you want to use (see "General Notes on Installation" section).

Mount your new DEDA ELEMENTI or MUD handlebar so that it is centered on the stem faceplate.

On road bikes, as a rule of thumb please remember that the lower flat part of the handlebars should run parallel to the ground or slant slightly downwards toward the ground.

Grease the faceplate bolts if needed (our bolts are pre-greased with esalock) and thread them by hand (just a few turns), being careful that surfaces between stem, faceplate and handlebar are not contaminated with grease.

Tighten the bolts so that the upper and lower clamping slots represent the same width.

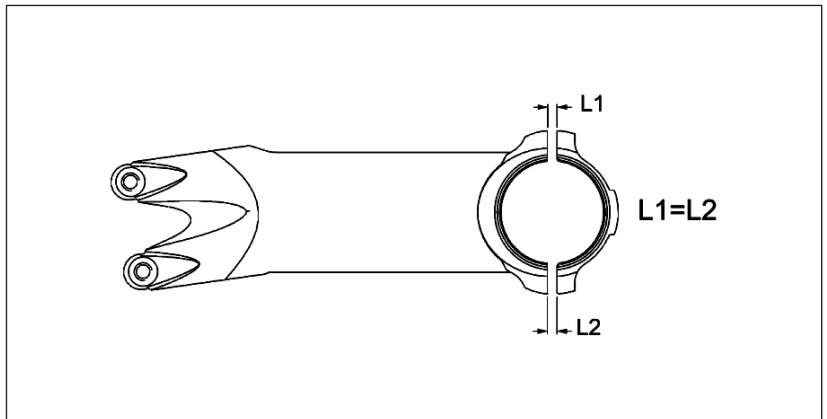

Then, using a torque wrench, tighten the bolts alternately in a cross pattern, turning $\frac{1}{2}$ turn at a time.

With the 4-bolt faceplates, tighten the bolts alternately in a 1-2-3-4 cross pattern, until a torque of $4 \text{ N} \cdot \text{m}$ is reached.

If your bike is equipped with a 2-collar faceplate tighten the bolts alternately in a 1-2 left/1-2 right pattern, until a torque of $4 \text{ N} \cdot \text{m}$ is reached.

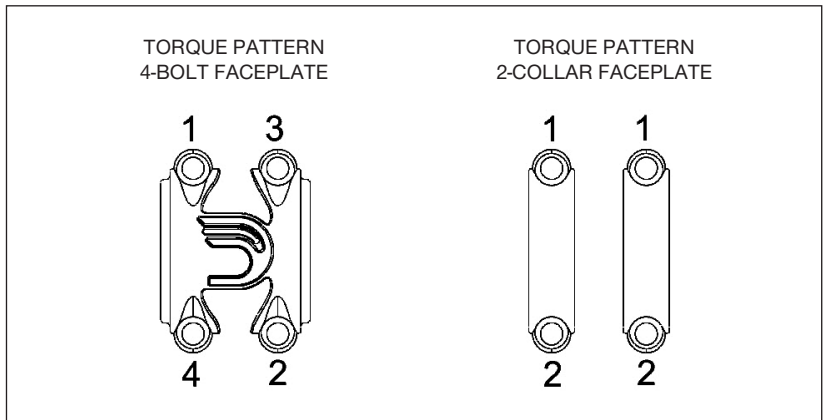

Check the symmetry and equality of all the distances between faceplate, body, handlebar stem, if necessary, further tighten up to $5 \text{ N} \cdot \text{m}$.

Check if the handlebar is secure on the handlebar stem. Please make sure that the handlebar is tight enough so that you can't twist it.

■ DEDA ELEMENTI and MUD components are designed to operate properly within a tightening range of 4 to $5 \text{ N} \cdot \text{m}$! If, in order to avoid relative rotation of fork steerer, stem and handlebar you must exceed these values, this means that the assembled are not compatible, or that grease and dirt have deteriorated the friction properties of the mating surfaces.

■ The value of $6 \text{ N} \cdot \text{m}$ indicated on some DEDA ELEMENTS and MUD stems should never be exceeded under any conditions of use.

Do not use shifter and brake lever that have burrs or sharp edges, as they can cut or make indentations in handlebars; loosen clamping bolts completely to ensure clamps are open all the way before sliding shifter and brake lever onto the handlebar.

Tighten clamp bolts to the prescribed maximum torque manufacturer's specifications.

Never rotate levers on a handlebar after you have significantly tightened the clamp bolts, or you will scratch its surface marring the finish and potentially risk damaging the handlebar.

FITTING THE BRAKE-SHIFTER LEVERS ON THE DEDA ELEMENTI HANDLEBARS

Before starting the installation of the shifter and brake levers on the Deda Elementi handlebars please check that they do not have burrs or sharp edges, as they can cut or make indentations in handlebars.

Install the brake levers following the instructions below:

- Loosen clamp fixing bolts completely before sliding shifter and brake levers along the handlebar
- Adjust the brake levers position with the clamp within the area identified by the graduated scale and tighten the clamp bolt using a torque wrench starting with a minimum torque of 6 Nm
- If the brake lever is not tight enough and rotates on the handlebar, increase the torque up to a maximum of 8 Nm

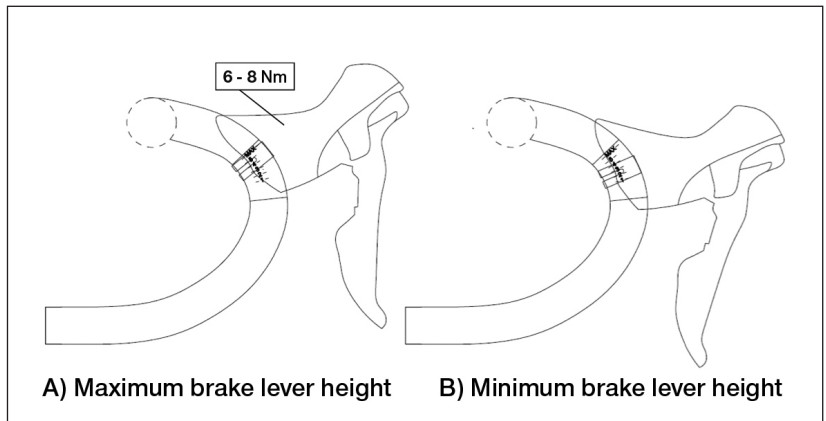

WARNING: Never rotate levers on a handlebar after you have significantly tightened the clamp bolts, or you will scratch its surface marring the finish and potentially risk damaging the handlebar.

WARNING: use the minimum tightening torque required to ensure that the brake levers do not rotate on the handlebar; in any case the tightening torque must exceed the 8 N/m.

An unnecessarily high torque generates a dangerous state of radial compression on the handlebar which can crack and/or break without notice.

WARNING: If, in order to avoid relative rotation of brake levers on the handlebar, you must exceed these values, this means that the assembled components are not compatible, or that grease and dirt have deteriorated the friction properties of the surfaces.

Regularly clean handlebar, stem, and seatpost with water and a soft cloth. Do not use harsh detergents such as acetone, trichloroethylene, solvents and other similar substances that may damage the finish and the substructure of the material.

While cleaning, look for cracks, scratches, deformations or discoloration. If you have any doubts please contact your local authorized DEDA ELEMENTI dealer.

Have damaged components replaced immediately.

Do not expose handlebar and handlebar stem to direct sunlight and high temperatures. Replace handlebar tape at least once a year.

Clean the handlebar with water and liquid soap. If necessary, remove the remains of adhesive with alcohol.

Check the handlebar for damage or corrosion.

For your safety, immediately replace any deteriorated or damaged components.

DEDA ELEMENTI components are guaranteed two years from the date of purchase for defects and workmanship.

This guarantee is only valid for the first buyer upon presentation of proof of purchase indicating date of purchase, address of the dealer, and name of the Deda Elementi product purchased.

This warranty does not cover damage resulting from:

- Installation of the component by non-qualified personnel.
- Installation of non-compatible components.
- Negligence (lack of care and maintenance).
- Accidents.
- Incorrect installation and overstress caused by improper use.
- Modification made to the component (e.g., shortened seatpost).

Deda
ELEMENTI **mus**

Deda
ELEMENTI

www.dedaelementi.com

Dedaindustrie S.r.l.
Via Leonardo Da Vinci 19/21/23
26010 Campagnola Cremasca (CR) - Italia
Phone +39 0373 750 129
Fax +39 0373 751 105

Dedaos

www.dedaos.com.tw

Deda OS
No.8, Lane 150-30, Sec. 3, Xitun Rd.,
Xitun Dist.
Taichung City 407, Taiwan (R.O.C.)
tel: +886-4-24623436
fax: +886-4-24623430

Deda Elementi USA
dedausa@dedaelementi.com

   #ridededa

